

SECTION L-5 Part A  
ISSUE 1, JANUARY 1953

# LUCAS

*Quality*

## EQUIPMENT

VOLUME 2

### WORKSHOP INSTRUCTIONS

#### MOTOR CYCLE MAGNETOS

MODELS NI, KNI, KIF, K2F and KVF



JOSEPH LUCAS LTD · BIRMINGHAM 19 · ENGLAND

Printed in England

# LUCAS WORKSHOP INSTRUCTIONS

## MOTOR CYCLE MAGNETOS

MODELS N1, KN1, K1F, K2F and KVF

### 1. GENERAL

The motor cycle range of general service magnetos consists of two basic designs, namely, base-fixed models and flange-fixed models. All models have wound rotating armatures and high-energy magnets cast integral with the bodies. Brief descriptions of current models are tabulated below:—

- N1** Base fixed magneto for use with single-cylinder engines. B.S.l. tapered driving spindle of centre-height 35 mm. Contact breaker actuated by a tappet and face type cam.
- KN1** Similar to Model N1, but centre-height of driving spindle 45 mm.
- K1F** Flange fixed magneto for use with single-cylinder engines. B.S.1 tapered driving spindle. Contact breaker actuated by ring type cam.
- K2F** Similar to Model K1F, but designed for use with twin-cylinder engines, excepting V-twins.
- KVF** Similar to Model K2V, but for use only with V-twin engines.

Small breathing holes are provided in the bodies of the above magnetos. These holes should not be allowed to become blocked.

Ignition timing is either fixed or variable. When provision for variable timing is made, one of two methods is adopted. These methods are Manual Control and Automatic (Centrifugal) Control. With the former method, the cam is moved relative to the armature, whereas in the latter method the armature is moved relative to the drive and for test purposes these magnetos are regarded as having fixed ignition timing.

With Manual Control, the position of the contact breaker cam can be varied by the rider by means of a Bowden cable connection to a control lever on the handle bars.

With Automatic Timing Control, the point of firing is fully retarded at start, and is advanced as the engine speed increases. This variation is effected by using a special driving gear carrying an inner plate fitted with two pins; a weight is pivoted on each pin, and each weight carries a pivoted toggle lever connected by a control spring to a pin at the pivoted end of the weight. An outer driving plate, secured by a central bolt to the magneto spindle, is provided with two pegs on its underside. These pegs locate with holes in the toggle levers.

When the magneto is stationary, the weights are in the closed position and the timing is retarded for

starting. When the engine fires and the speed of the drive increases, centrifugal force acting on the weights overcomes the restraining influence of the spring. The weights, moving outwards, cause relative movement to take place between the driving gear and the magneto spindle, and in this way cause the timing to be advanced. The range of movement is limited by stops provided on the driving plate.

The springs selected are matched to suit individual engine models in order that this form of control will conform closely to the changing requirements of the engine.

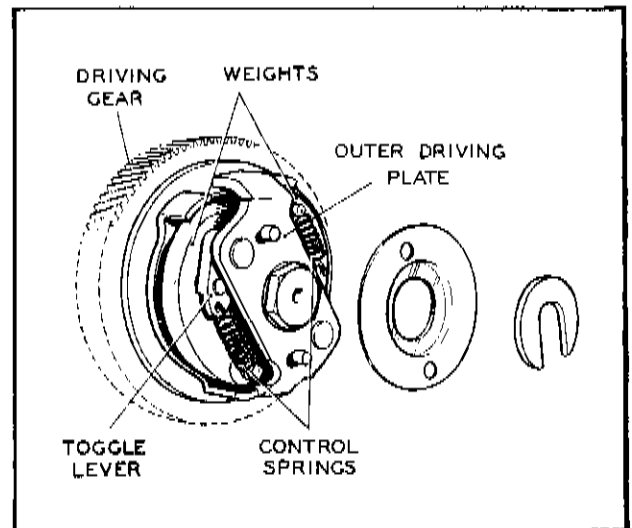

Fig. 1.  
An automatic timing control mechanism

### 2. ROUTINE MAINTENANCE

(a) **LUBRICATION.** To be carried out every 3,000 miles.

#### (i) Magnetos with Ring Type Cam

Wipe the outside of the magneto to remove dirt or grease, and then take off the contact breaker cover. Unscrew the hexagon headed screw in the centre of the contact breaker and withdraw the contact breaker from its housing. Push aside the contact breaker arm retaining spring and prise the arm off its pivot. Wipe away any dirt or grease from the contacts with a petrol-moistened cloth.

If necessary, use a very fine carborundum stone to polish the contacts, re-cleaning afterwards with a



# LUCAS WORKSHOP INSTRUCTIONS

petrol-moistened cloth. Smear the pivot pin with a little Mobilgrease No. 2 before refitting the contact breaker arm.

Remove the cam ring, which is a sliding fit in its housing, and lightly smear inside and outside surfaces with Mobilgrease No. 2. Both removal and refitting of the cam can be made easier if the handlebar control lever is half retarded, thus taking the cam away from its stop pin. Apply one or two drops of thin machine oil to the felt cam lubricator in the housing. Refit the cam, taking care that the stop peg in the housing and the plunger of manual timing controls, engage with their respective slots.

Refit the contact breaker. This can be made easier if the contact breaker heel is away from the cam lobe; turn the engine until this is so. The key on the projecting part of the contact breaker base must engage with the keyway in the armature shaft. Refit the hexagon headed screw and tighten with care. It must not be slack, neither must undue force be used.

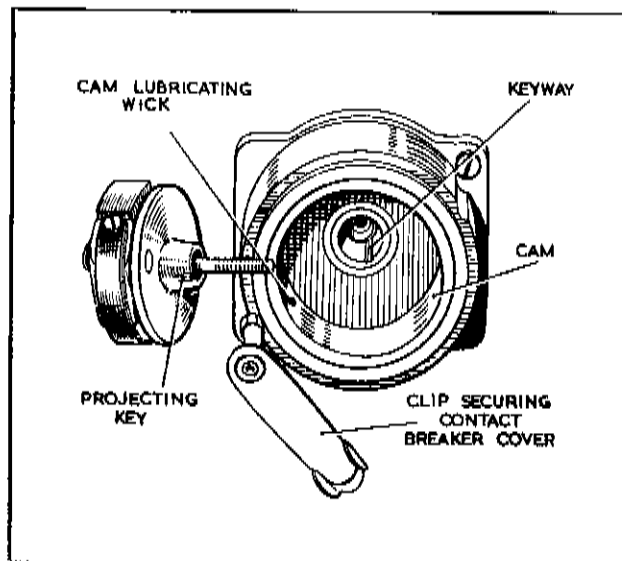

Fig. 2.  
Contact breaker with ring type cam

## (ii) Magnetos with Face Type Cam

The cam is lubricated by a wick located in the contact breaker casting. To reach the wick, remove the backing spring and spring arm by withdrawing the single securing screw. The wick is carried in a hollow hexagon-headed screw which can now be withdrawn. Take care not to lose the insulating washer or tube. Moisten the wick with a few drops of thin machine oil and refit the hollow screw.

At this stage, bend back the brass locking tag from the hexagon head of the contact breaker securing screw and withdraw the screw. The contact breaker can now

be removed. Take out the tappet which actuates the spring arm and lightly smear it with thin machine oil. Extract the wire ring and remove the face cam. Lightly smear both sides of the cam with Mobilgrease No. 2.

Refit the cam, taking care that the stop peg in the housing and the plunger of the timing control engage with their respective slots. Note that a recess is provided for the 'eye' of the wire ring.

Check that the tappet moves freely in the contact breaker casting.

Thread the special tag washer on the contact breaker securing screw, and place the flat edge of the washer against the location provided for it in the contact breaker casting. Tighten the screw and lock it by bending the tag washer against one of the hexagon flats.

Wipe away any dirt or grease from the contacts with a petrol moistened cloth. If necessary, use a very fine carborundum stone to polish the contacts, re-cleaning afterwards with a petrol moistened cloth.

Refit the spring arm and backing spring. The bent portion of the spring arm must curve outwards. Place a lock washer over the fixing screw and tighten.

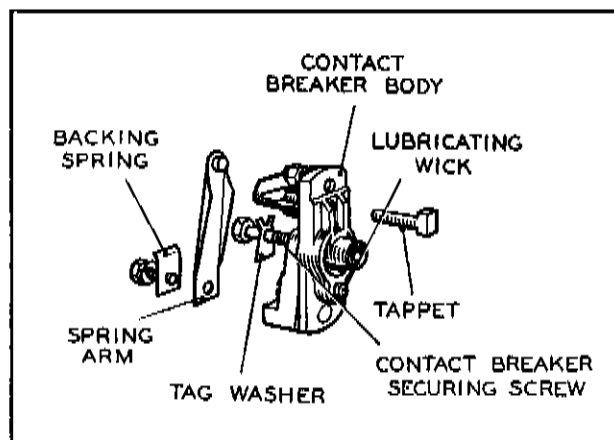

Fig. 3.  
Contact breaker for use with face type cam

## (iii) Bearings

The main bearings of the magnetos are packed with grease during manufacture and need no attention until a general overhaul is undertaken.

(b) ADJUSTMENTS. Check every 3,000 miles.

### (i) Setting contact breaker gap

The contact breaker gap must be set to 0.012"-0.015" when the contacts are fully separated.

To adjust the gap, turn the engine until the contacts are fully opened. Slacken the locking nut of the



# LUCAS WORKSHOP INSTRUCTIONS

adjustable contact, and turn the contact by its hexagon head until a feeler gauge of appropriate thickness is a sliding fit in the gap. Tighten the lock nut and recheck the gap.

## (ii) Adjusting the Timing Control Cable

When manual control of timing is fitted, any slackness in the cable can be taken up by sliding the waterproofing rubber shroud up the cable and turning the hexagon headed cable adjuster. After adjusting, return the rubber shroud to its original position over the adjuster and central barrel.

(c) CLEANING. To be carried out every 6,000 miles. Check the contact breaker contacts and, if necessary, clean them as described in Para. 2 (a). Wipe the outside of the magneto to remove dirt or grease. Check the cable adjuster and control barrel (when fitted) for signs of water ingress.

Remove the high tension pick-up or pick-ups and polish with a soft dry cloth. The carbon brush must move freely in its holder and, if necessary, clean it with a petrol moistened cloth. Should the brush be worn to within  $\frac{1}{8}$ " of the shoulder it must be renewed. Whilst the pick-up moulding is removed, clean the slip ring track and flanges by holding a soft dry cloth against them with a suitably shaped piece of wood while the engine is slowly turned.

The high tension cable or cables must be kept clean and dry.

## (d) RENEWING HIGH TENSION CABLES

If, on inspection, the high tension cable shows signs of deterioration, it must be replaced, using 7 mm. rubber covered ignition cable.

To fit a new high tension cable, bare the end for about  $\frac{3}{8}$ ", thread the knurled moulded nut over the cable, and thread the bared cable through the washer removed from the old cable.

Bend back the strands radially, and screw the nut into the pick-up moulding.

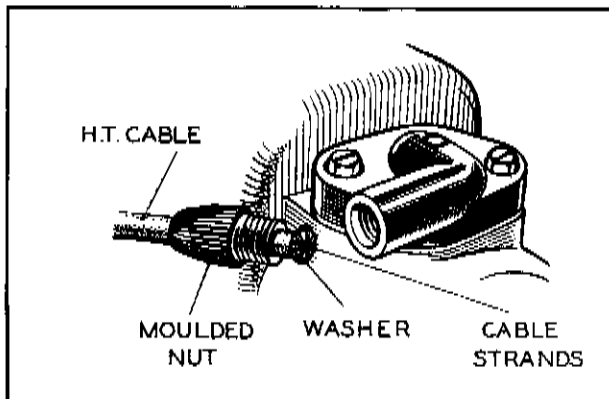

Fig. 4.

Renewing H.T. or Ignition cut out switch cable

## (e) RENEWING TIMING CONTROL CABLE

The Bowden timing control cable (when fitted) should be renewed if it becomes frayed, otherwise moisture may enter the contact breaker housing.

To do this, slip back the rubber shroud and, by means of the hexagon at the base, unscrew the control barrel. If the cable and the plunger to which it is attached are now pulled upwards, the cable nipple can be disengaged from the plunger slot.

Soften the solder and remove the nipple.

Thread the new length of cable through the rubber shroud, cable adjuster, control barrel, sealing washer and restoring spring. Solder the nipple to the end of the cable. Engage the nipple with the slot in the plunger and screw the control barrel into the body, ensuring that the sealing washer is correctly fitted between the barrel and the body.

Take up any slackness in the cable by means of the adjuster before refitting the rubber shroud in position.

## (f) CONTACT BREAKER SPRINGS

Correct contact breaker spring pressures, measured at the contacts, are 18-24 oz. with ring type cams and 28-36 oz. with face type cams.

## 3. SERVICING

### (a) TESTING MAGNETO IN POSITION ON ENGINE

To locate cause of misfiring or failure of ignition, check as follows:

(i) Remove the sparking plug or plugs from the engine. Hold the end of the H.T. cable about  $\frac{1}{8}$ " from the cylinder block and crank the engine. If strong and regular sparking is produced the fault lies with the sparking plug or plugs which must be cleaned and adjusted or renewed.

(ii) If no sparking is produced, examine the H.T. cable and, if necessary, renew it as described above in Para. 2 (d).

(iii) Very occasionally, the fault may be due to a cracked or punctured pick-up moulding. This type of fault is not easily detected by inspection, and a check should therefore be made by substitution.

(iv) If an ignition cut out switch is fitted, disconnect the cable at the magneto and retest. If the magneto now functions normally the fault is in either the cable or the cut out switch. Correct by replacement.

(v) If the magneto has recently been replaced or removed, it may be incorrectly timed. Refer to the engine makers' instructions, and check.

(vi) Check the contact breaker for cleanliness and correct contact setting as described under Maintenance.

If the cause of faulty operation cannot be traced from the foregoing checks, the cause may be an internal defect in the magneto. The magneto should therefore be removed from the engine for dismantling.



# LUCAS WORKSHOP INSTRUCTIONS

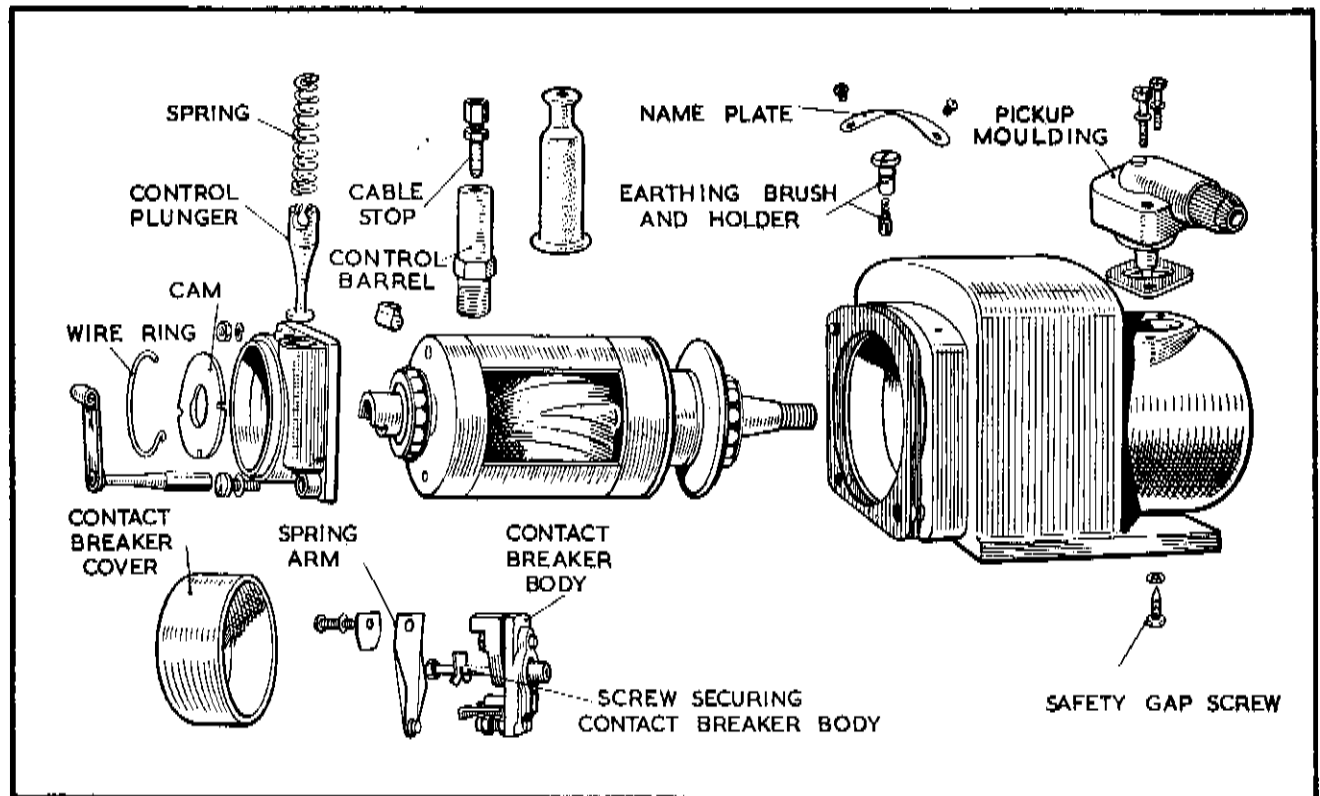

Fig. 5.  
Typical base fixed magneto, dismantled

## (b) DISMANTLING

### Important:

The following dismantling, testing and reassembly procedures must be carried out while **working at a clean bench**.

(i) Remove the earthing brush and (when fitted) the safety gap screw or screws. Failure to remove these parts will cause damage to the armature, when the latter is withdrawn from the magneto body. The earthing brush is under the nameplate at the contact breaker end of base-fixed magnetos, and near the flange at the driving end of flange-fixed magnetos.

A safety gap screw (when fitted) is recessed in the base at the driving end of single-cylinder base-fixed magnetos — a second earthing screw being fitted opposite to the first, in the case of twin-cylinder models. The safety gap screw in single-cylinder flange-fixed magnetos is fitted in the underside at the contact breaker end — a second screw being fitted in the upper side, in the case of twin-cylinder models.

(ii) Remove the H.T. pick-up moulding or mouldings, taking care to retain the gasket for use when re-assembling.

(iii) Remove the contact breaker and cam as described in Para. 2 (a).

(iv) If manual ignition timing control is fitted, remove the rubber shroud, cable, cable adjuster, control barrel, sealing washer, plunger and restoring spring as described in Para. 2 (e).

(v) Take out the screws securing the contact breaker housing to the magneto body and unscrew the pillar carrying the cover retaining spring. The contact breaker housing is now free to be withdrawn from the magneto body, but care must be taken to retain the sealing gasket and shims for use when re-assembling.

(vi) Withdraw the armature from the magneto body. The high-energy magnet in the latter does not need a keeper across it; although a very small amount of energy is lost at the first removal of the armature, subsequent removals do not affect it.

**Do not place the magneto body or armature near to iron filings, always work on a clean bench.**

(vii) Examine the armature for signs of damage. A faulty winding or condenser can only be detected by the tests given later.



# LUCAS WORKSHOP INSTRUCTIONS

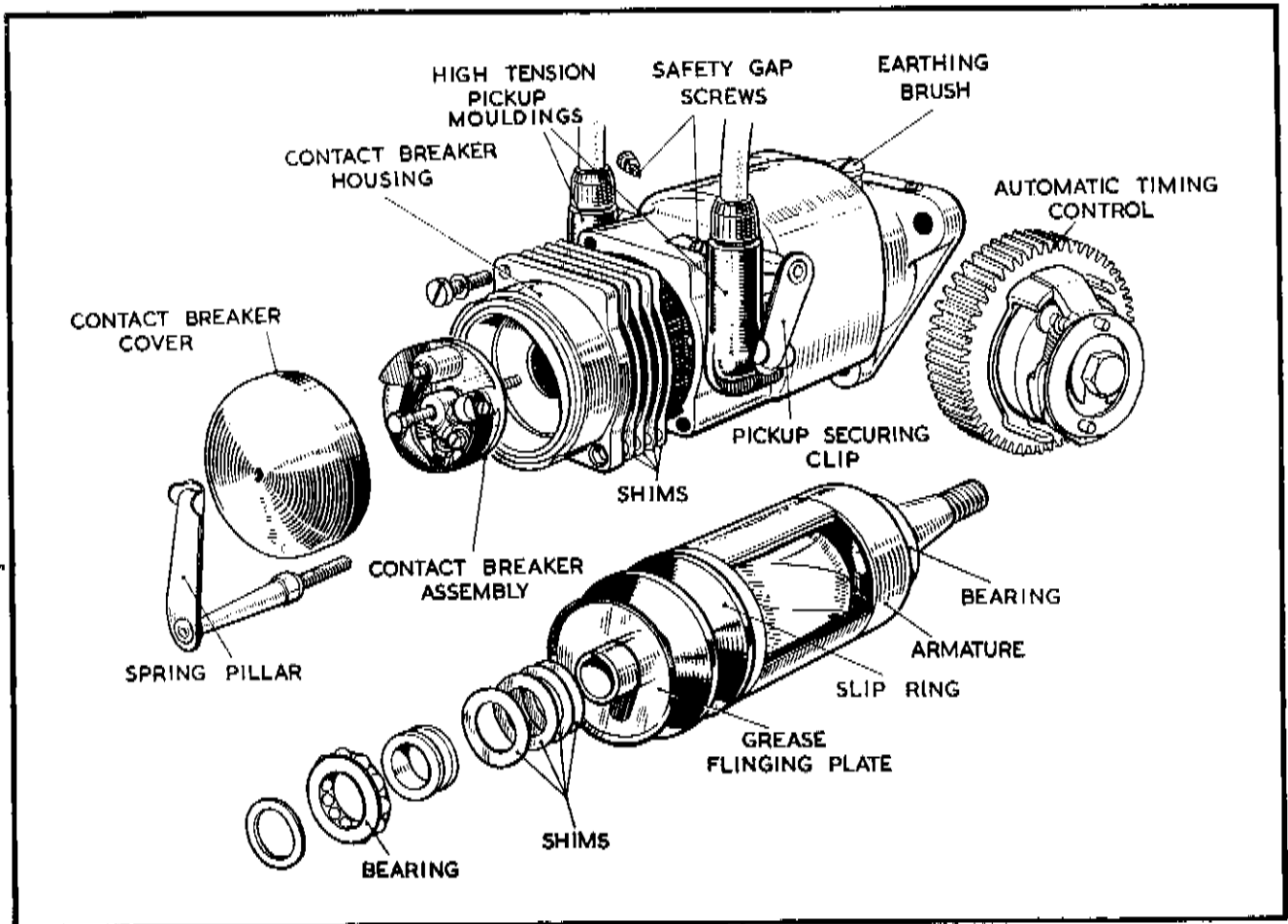

Fig. 6.  
Typical flange fixed magneto, dismantled

(viii) It is important that the two ball bearings supporting the armature are in good condition. These are packed with grease during manufacture and will stand an almost unlimited period of normal running. If, however, the shaft is bent, the bearings may begin to fail and need replacing.

The balls and cages can be pulled off the inner races without difficulty, and the inner races removed from the armature shaft using an extractor. The outer races can be removed with an expanding collet type extractor or by the use of a tool as shown in Fig. 7.

(ix) Examine the slip ring and moulding. If these show signs of burning, tracking or other damage, a new slip ring unit must be fitted. To do this, remove the bearing adjacent to the slip ring, shims, grease flinging plate and defective slip ring unit.

**Note:** When removing the inner race, the extractor must bear on the brass shaft extension and

not on the electric contact or on the insulator inside the shaft. A disc of appropriate diameter can be placed across the face of the shaft extension.

Carefully straighten the wire coming from the armature and check that it is clean. Fit the new slip ring moulding on the shaft, taking care that the wire enters the hole in the slip ring boss, and that it goes fully home without bending. Seal the wire into the boss with varnish; a special air drying varnish is used during manufacture, though shellac may be used if the former is not available.

Refit the grease flinging plate, the correct number of shims, and the inner race of the bearing.

## (c) TESTING THE ARMATURE

### (i) Checking Continuity of Primary Winding and Insulation



# LUCAS WORKSHOP INSTRUCTIONS

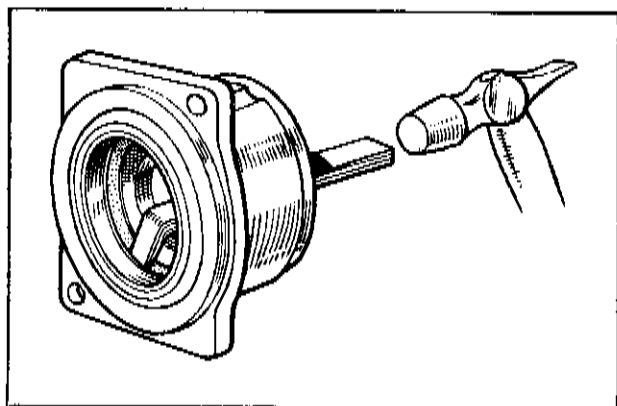

Fig. 7.  
Removing bearing outer race

A continuity check of the armature primary winding can be made using 0—10 amp. ammeter and a two-volt supply, e.g. a tapping across one cell of a lead-acid battery.

Screw the contact breaker retaining screw for a small distance into the end of the armature shaft.

**Note:** If the screw is screwed right home in the case of base-fixed magnetos there will be a danger of contacting and damaging the condenser.

Connect one terminal of the battery to one terminal of the ammeter.

Connect the second battery terminal to the metal body of the armature.

Contact the second terminal of the ammeter with the screw in the armature shaft.

The ammeter should indicate approximately 4 amperes. If a current differing appreciably from 4 amperes is indicated, a replacement armature must be fitted.

An insulation test, using a 500 volt insulation tester, should give a reading of not less than 10 megohms.

### (ii) Simple Check of Secondary Winding

If test apparatus is not available, leave the connections as described for the primary winding continuity check and proceed as follows:

Take a 15" length of H.T. cable and bare one end for about  $\frac{1}{2}$ " and the other end for about 4".

Wrap the longer bared end about the slip ring brass insert, taking care not to damage or scratch the brush track. Holding the other end about  $\frac{1}{8}$ " from the armature shaft, flick the end of the wire from the battery against the armature shaft.

Failure to spark indicates a fault either in the armature windings or in the condenser. In either case a replacement armature must be fitted.

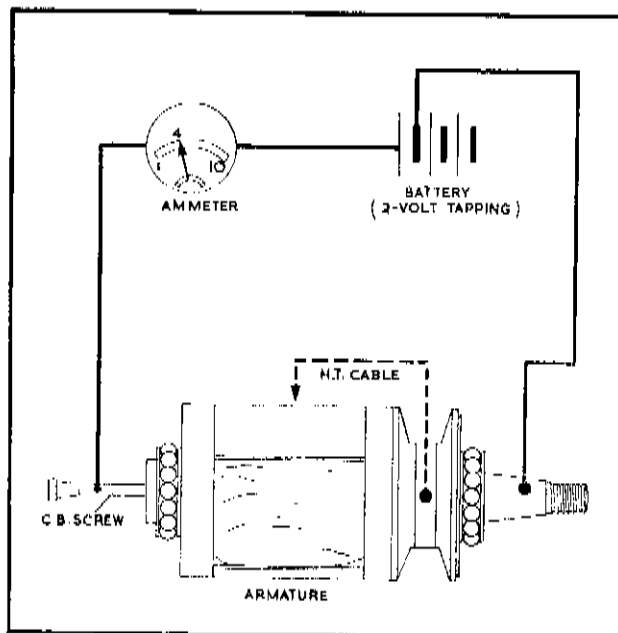

Fig. 8.  
Connections for primary winding continuity test (additional connection for secondary winding sparking test shown in broken line)

### (iii) Checking Performance and Insulation

Connect in series an 8 volt accumulator, e.g. a tapping across four cells of a 12-volt lead-acid battery, a contact breaker actuated by a four lobed cam having a 45° closed period, and the armature primary winding—the contact breaker-to-primary connection to be at earth potential. Connect a 0.2 mfd. condenser across the contact breaker contacts.

Connect a high tension cable between the brass slip ring insert, taking care not to damage or scratch the brush track, and either a 3-point spark gap or a rotary gap set to 14 k.v.

Run the contact breaker cam at 750 r.p.m. to give 3,000 operations of the contacts per minute.

Regular sparking should occur. Explore the taped surface of the armature windings with an earthed pointer. No flash-over must take place.

If the windings are in order, sparking can occur even if the condenser inbuilt with the armature is defective. Disconnect, therefore, the external condenser. If sparking now ceases or is irregular, the internal condenser is defective and a replacement armature must be fitted.

### (iv) Checking Maximum Primary Running Current

If a satisfactory performance is not obtained in the foregoing test, measurement should be made of the



# LUCAS WORKSHOP INSTRUCTIONS

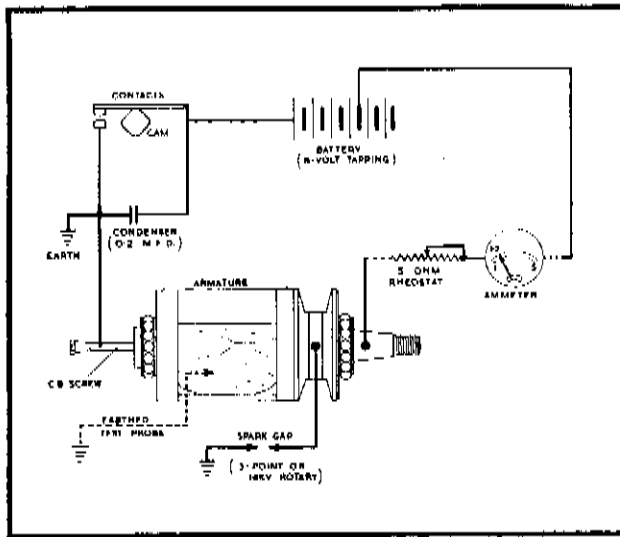

Fig. 9.

\* Connections for performance check of armature, using a separately driven contact breaker (earthed probe, and connections for checking primary winding running current, shown in broken line)

maximum primary running current. To do this, include in the primary circuit a moving coil ammeter having a full scale deflection of not more than 5 amperes, together with a variable series resistance of approximately 5 ohms and of suitable current rating.

Run the contact breaker as before and adjust the variable resistance until occasional missing occurs, i.e. when the armature is just failing to produce a regular spark. The ammeter should then indicate a current of not more than 1.2 amperes. If a current reading differing appreciably from this figure is given, the armature must be replaced.

**Note:** Under no circumstances must the condenser or its connections be disturbed.

It is important, when carrying out either of the foregoing tests, to maintain a constant 8 volt supply and a constant cam speed; also, that the armature is free from external magnetic fields, e.g., it must not be tested on an iron bed plate or bench.

## (d) REASSEMBLY

### (i) Cleaning and refitting bearings and oil seals

The inner and outer bearings are matched and carefully run-in during manufacture and it is essential that neither the cages nor the races become interchanged end for end during reassembly. As a precaution, remove, clean and replace the bearings one at a time. It should be possible to withdraw the bearings without effort.

The cages should be washed in clean petrol and afterwards dried. The inner races should not be removed from the armature shaft unnecessarily.

When an inner race has to be removed, it can be refitted using a hand press and a length of tubing fitted over the shaft and locating on the race. Lightly pack the cages with high melting point grease, before refitting them to the inner races. If the outer races have been removed, place a new oil seal in the bearing housing at the driving end of the magneto body. Press the outer races into their housings with a mandrel of the type shown in Fig. 10, taking care that a serrated insulated washer is positioned between each race and its housing. More than one insulated washer

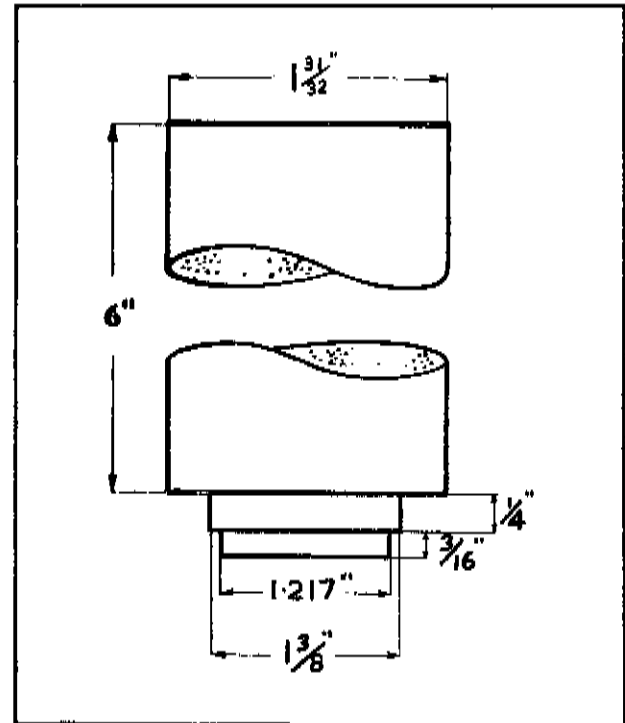

Fig. 10.

Mandrel for fitting bearing outer race

may be used to ensure a tight fit of the race in its housing.

**Note:** Oil seals may be cleaned only in light lubricating oil, **not** in petrol or paraffin.

(ii) Check that the slip ring moulding and insert are clean, and that the interior of the magneto body is free from swarf, etc. Insert the armature into the body, shaft end first.

(iii) Refit the contact breaker housing, taking care that the end plate shims are in position, and tighten the securing screws.

(iv) Check the armature for end float. It should rotate freely when turned by hand but no end play





# LUCAS WORKSHOP INSTRUCTIONS

should be present. If necessary, add or remove shims behind the contact breaker end plate until correct armature rotation is obtained.

Shims are available of 0.003" and 0.005" thickness. The actual amount of end float allowed depends on the type of cam fitted. With ring type contact breakers an end float of 0.001" to 0.005" is allowed. With face type contact breakers, an armature end float of 0.001" to 0.003" is permitted.

(v) Refit the cam and contact breaker as described in Para. 2 (a) and set the contact gap to 0.012" to 0.015" with the contacts fully open. Refit the contact breaker cover.

(vi) Check that the H.T. pick-up or pick-ups are clean and that the H.T. brush moves freely in its holder. Lightly smear the seating surface of the magneto body with grease before fitting the cork washer and screws.

(vii) Check that the earthing brush or brushes move freely in their holders, and refit.

(viii) Refit the safety gap screw or screws. The distance from the tip of a screw to the slip ring should be  $6\frac{1}{2}$ — $7\frac{1}{2}$  mm. Refit the name plate if removed.

(ix) Refit auto-advance unit (when carried).

**Note:** When refitting or replacing an auto-advance unit, do not press the unit right home on the armature driving taper, but allow the retaining bolt to do this as it is tightened. In this way, the danger of locking the retaining bolt before the auto-advance unit is fully engaged on the taper, or of accidentally engaging the extractor left hand thread with the retaining bolt, will be avoided.

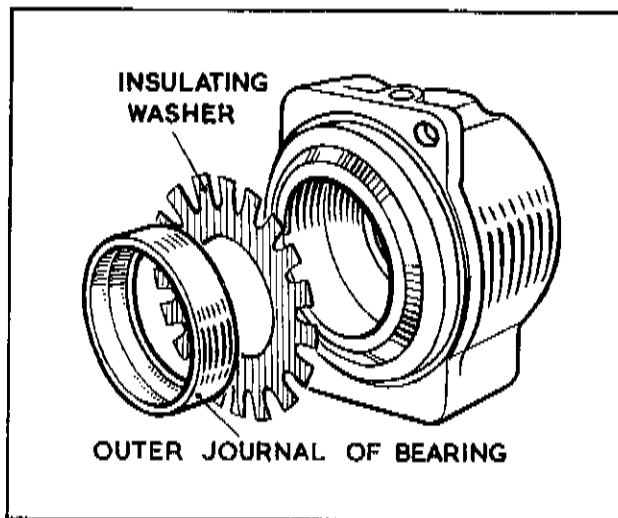

Fig. 11.  
Position of serrated insulating washer

(x) **Remagnetisation.** Normally, remagnetisation will not be necessary but, should it be considered so, full instructions will be found in Section D-6 of the Lucas Workshop Manual.

(xi) Carry out the tests and inspections specified below. In the event of a magneto failing to perform satisfactorily any of these tests, it must be returned to the Works for examination.

## Endurance Test

With the contact breaker cover in place, run the magneto for one hour at 3,000 r.p.m. with the H.T. cable or cables connected to an 8 k.v. annular spark gap.

## Inspection

After the above run, disconnect the magneto and examine it as follows:—

Remove the pick-up or pick-ups and check for signs of sticking brushes, and for flashover or of fouling against the slip ring moulding.

Examine the slip ring for signs of flashover, burnt or rough track, presence of swarf or of eccentricity. Remove the contact breaker cover and check as follows:—

**Ring type cams:** The contacts should be in line and the maximum gap to be 0.012" to 0.015". The earth brush, when fitted, should be free to move in its holder. The contact breaker arm must be free to rock on its pivot. All screws must be tight, and the contacts must not begin to open before  $3^\circ$  after the magnetic pull.

**Face type cams:** The contacts should be in line and the maximum gap to be 0.012" to 0.015". The tappet must move freely in its holder. All screws must be tight.

Remove the earthing brush and check that it is free to move in its holder.

Check for excessive end float or any blinding of the armature.

## Safety Gap Test

If the magneto is fitted with a spark gap or gaps, remove the H.T. cable and run for 30 seconds at 1,000 r.p.m. in the case of magneto models N1 and KN1, or at 1,800 r.p.m. in the case of magneto models K1F, K2F and KVF.

## Inspection

After the above run, remove the H.T. pick-up or pick-ups and examine for signs of tracking or flashover at the slip ring.

## High Speed Test

Connect the H.T. cable or cables to a rotary gap.



# LUCAS WORKSHOP INSTRUCTIONS

set as shown in SB 222 Section 4 to 8 k.v. using a  $2\frac{1}{2}$  micro-mho load. Remove the contact breaker cover. No missing must occur over a speed range of 1,000—3,000 r.p.m. Watch the contact breaker gap for excessive sparking.

While running at 3,000 r.p.m. the primary winding should be short-circuited at least six times, by touching the rotating contact breaker with an earthed cable.

### Low Speed Test

Connect the H.T. cable to a 3-point spark gap set to 5.5 mm. Use independent spark gaps in the case of twin-cylinder magnetos. Not more than 5% missing must occur at the following speeds:—

Models N1 and KN1	...	130 r.p.m. (advanced)
		170 r.p.m. (retarded)

### Models K1F and K2F

Fixed Ignition or Auto-Advance 130 r.p.m.

Manual Control	...	...	110 r.p.m. (advanced)
			150 r.p.m. (retarded)

Model KVF	...	...	...	130 r.p.m.
-----------	-----	-----	-----	------------

### Automatic Advance Characteristics

These figures, when applicable, will be provided by the Service Department on receipt of the model and service number of the magneto.

